



FLEXIRIP COMPACT

FlexiRip Compact technical data: Standards and options

This table shows the basic technical data and features of the FlexiRip Compact.
Your WEINIG Expert will be happy to provide you with more specific information.

Cutting length	5,200 mm
Working width	450 mm
Max. cutting height	140 mm
Motor power (option)	11 (15) kW
Rotation speed	2,900 rpm
Saw blade diameter min./max.	400 – 500 mm
Saw blade bore	80 mm
Feed speed	0 – 60 m/min
Dimensions: length x width x height	7.40 x 1.35 x 1.6 m
Working height	900 mm
Required dust extraction speed	30 m/sec.
Dust extraction diameter	2 x 160 mm
Required dust extraction volume	4,340 m ³ /h
Laser 30 mW	●
EasyFix saw blade fast-release system	●
Protective lamellae 8 mm, profiled	●
Workpiece hold-down unit, length 3,000 mm	●
Wooden insert for hold-down unit	●
Motorised fence adjustment	●
Zero-cut equipment	●

Subject to technical modification. Statements and pictures in this brochure may also include optional extras which are not included in the standard serial equipment. Some of the photos show the machine with the protective covers removed.

● Standard

FLEXIRIP COMPACT

The compact machine concept
for efficient, economical ripping



RAIMANN HOLZOPTIMIERUNG
GMBH & CO.KG
Weisserlenstrasse 11
79108 Freiburg
Germany

Phone +49 (0) 7 61 / 1 30 33-0
Fax +49 (0) 7 61 / 1 30 33-17
info@weinig.com
www.weinig.com

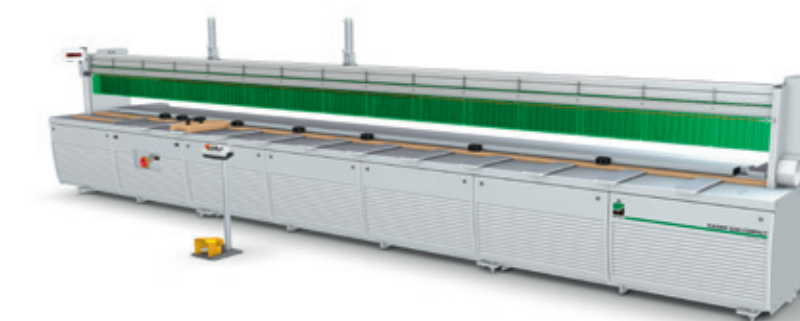

WEINIG FlexiRip Compact RaimannLine: The synonym for flexibility

The standard model of the FlexiRip stands for universal use in small and medium sized companies – anywhere planks, boards or panels are cut to size. The efficient length cutting saw with its good reputation is appreciated by customers because of its high flexibility, the optimum material yield and the one-man operation. FlexiRip Compact is the solution when universal use is required!

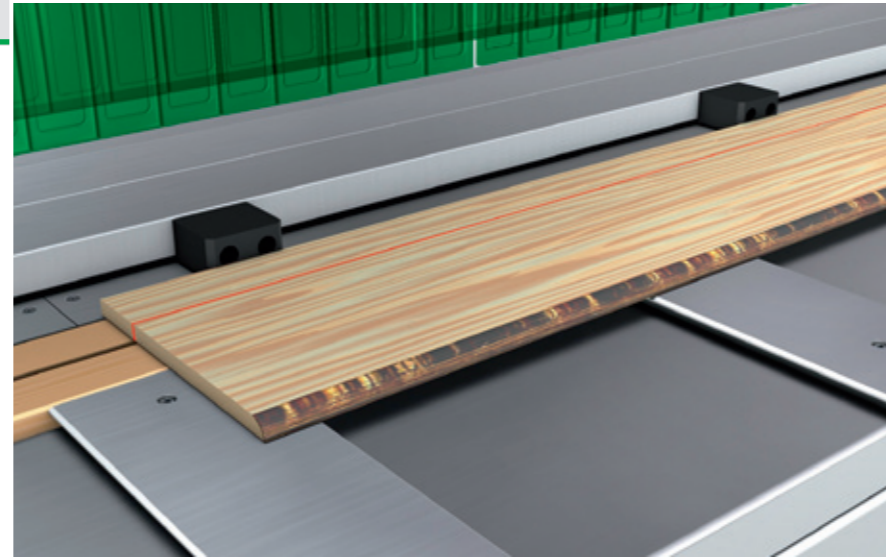

Positioning fence

The positioning fence is adjusted using a wear-resistant tooth belt system. This guarantees an even travel of the fence, as well as accurate positioning - even when pushing heavy material.

Push-buttons in a mobile operator panel enable easy adjustment of the fence. Combined with a large, easy to read digital display positioning the fence becomes child's play.



Advanced standard features

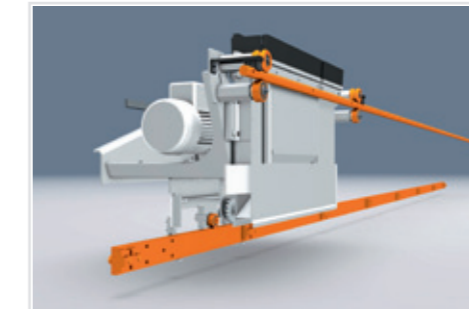

Dual guiding system for optimum cutting results

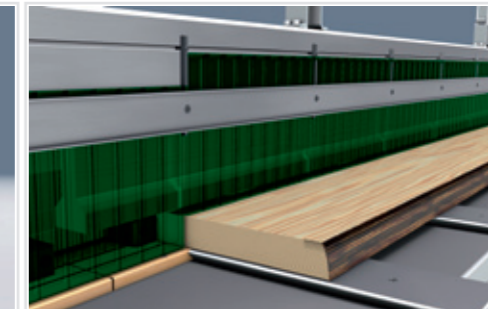

Safety beam with lamellae for maximum operator safety

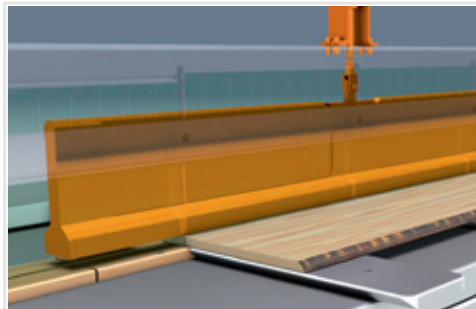

Hold-down unit for optimum cutting quality



Laser – see what is being cut



Stop block for easy fixation of the workpiece

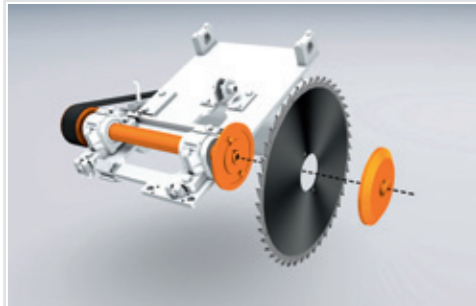

EasyFix – saw blade fast-release system

The FlexiRip Compact offers many competitive advantages:

- Efficient, powerful performance
- Extremely flexible for a multitude of jobs
- Optimum material yield
- Comfortable one-man operation
- Quick saw blade changes
- High operator safety



Applications

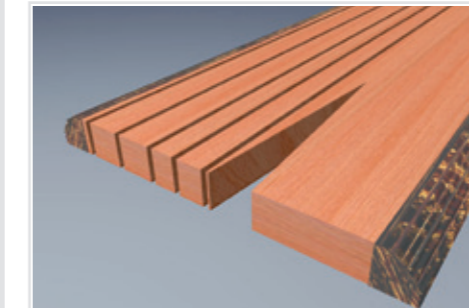

Unedged board ripping

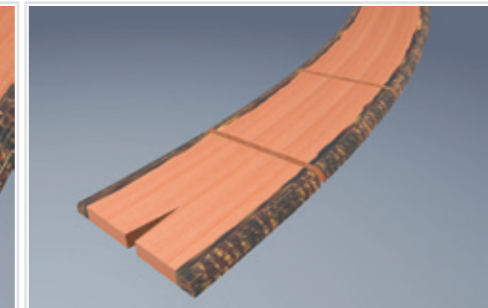

Rough cross cuts

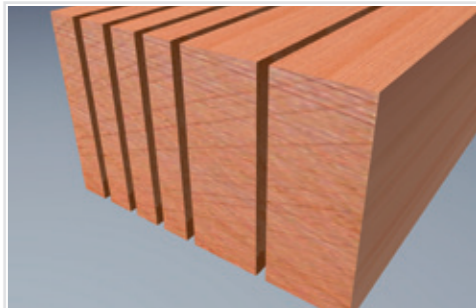

Thin strip ripping

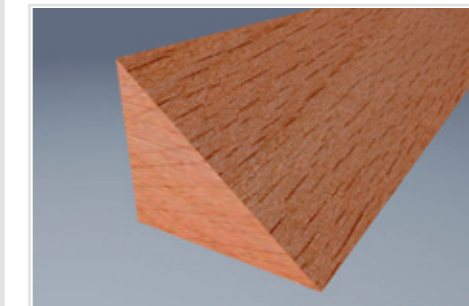

Bevelled cuts



Mitre cuts and cut-outs

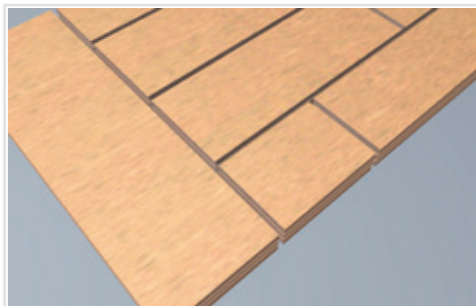

Cutting panels